

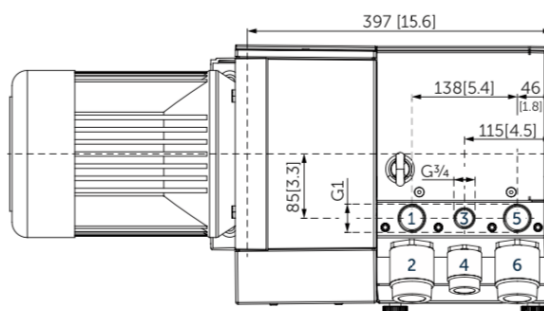

Model: **DVT3.80**

SPECIFICATIONS

Volume flow 50 Hz	70 m ³ /h
Pressure/Vacuum relative 50 Hz	±0.5 bar/±0.6 bar
Power 50 Hz	4.0 kW
Noise Level 50 Hz	75...76 dB(A)
Volume flow 60 Hz	82 m ³ /h
Pressure/Vacuum relative 60 Hz	±0.5 bar/±0.6 bar
Power 60 Hz	4.5...4.8 kW
Noise Level 60 Hz	76...77 dB(A)
Weight	49 kg without motor

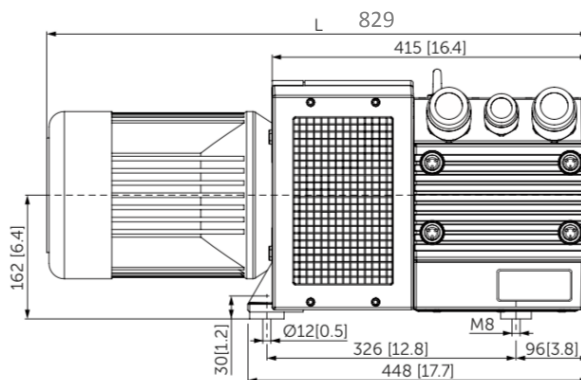
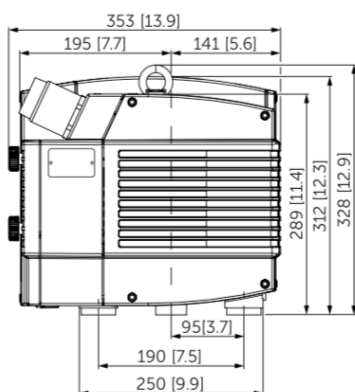

- 1 Pressure connection (G1)
 - 2 Pressure regulating valve
 - 3 Option: second suction (G³/₄)
 - 4 Option: vacuum regulating valve for second suction
 - 5 Vacuum connection (G1)
 - 6 Vacuum regulating valve
- Including integrated suction air filter
 - The motor illustration may vary.
 - Dimensions in mm [inch]